

LANDING STAR T2

LED light for UL aircraft, round type



Product description:

LANDING STAR T2 LED light is intended to be used as landing light and to be installed in the wing, **behind the cover glass**. When used it illuminates the runway.

Usage: Any aircraft with 12V (nominal) electrical system.

THIS PRODUCT IS NOT APPROVED FOR INSTALLATION ON CERTIFIED AIRCRAFT. THIS IS NOT A TSO CERTIFIED LIGHT.

THE METAL BODY OF THIS PRODUCT MUST BE INSULATED FROM (GROUNDED) METAL PARTS OF THE AIRCRAFT (MUST NOT BE CONNECTED TO ANY ELECTRICAL POTENTIAL).

A ferrite bead is also supplied with the product. This is usually mounted on the reflector when using WIG-WAG and is used to suppress unwanted interference that mainly penetrates the audio. It can always be installed as a precaution, but it is not necessary. It is installed by passing the power wires twice through the bead to 2-10 cm from the body of the reflector. Instructions for using the ferrite bead can be downloaded from www.lambert-aerodevices.cz.

LED light dimensions:

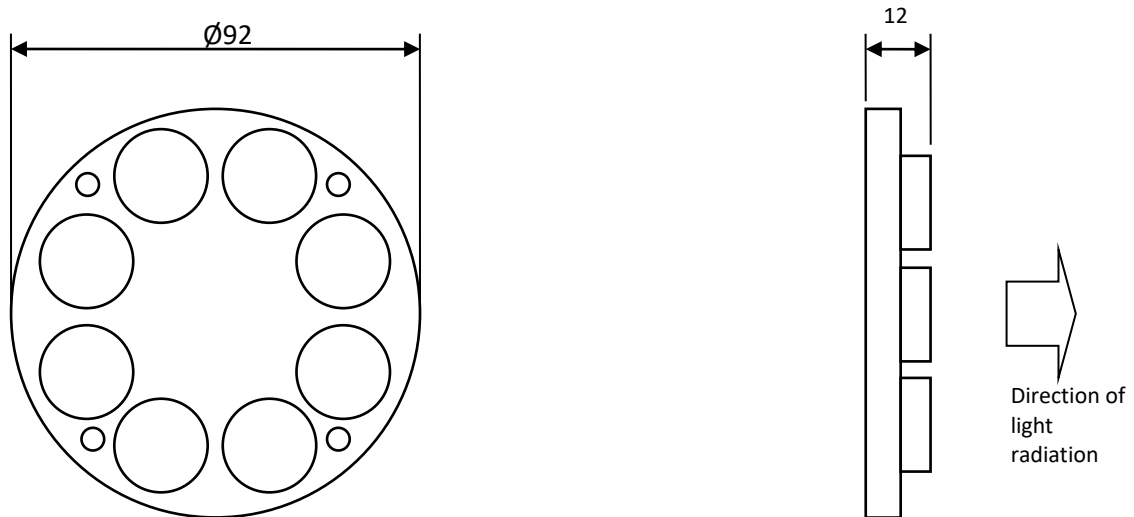

Fixing points positions and dimensions:

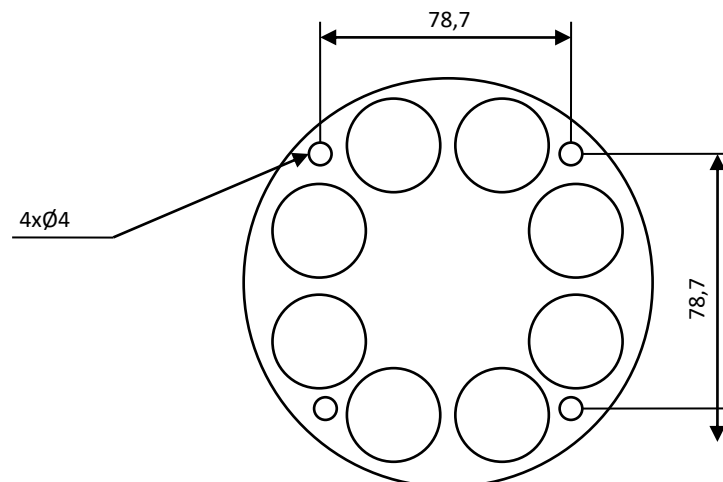

All dimensions are in mm.

Radiation characteristics:

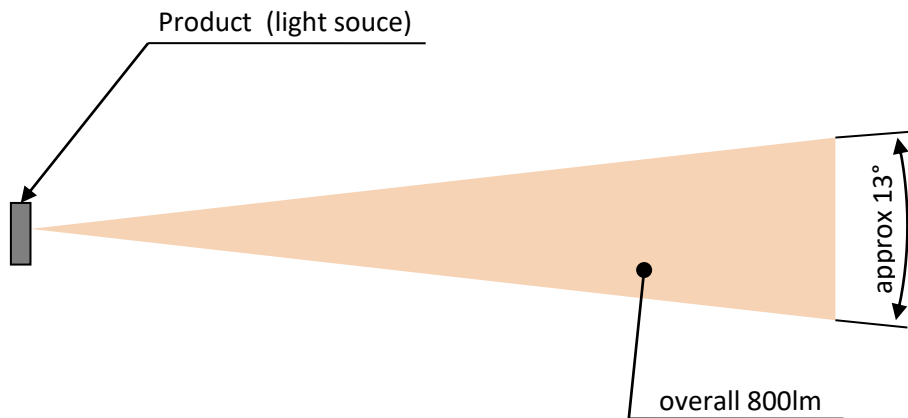

Note: angle is spheric

Basic characteristics:

Parameter	Value	Units	Note
Dimensions	∅92 x 12	mm	
Weight	88	g	
Overall light output	800	lm	
Ambient teperatures	-20 ÷ +50	°C	Operating condition

Electrical parameters:

Parmeter	Min	Typ	Max	Units	Note
Operating Voltage	8	12	18	V	
Current consumption		1.911		A	@8V
		0.920		A	@12V
		0.786		A	@14V
Recommended FUSE protection		5		A	

Conductors labeling and wiring:

Conductor label	Wire to	Note
+12V	+12V positive supply from battery	+ pole of the battery
GND	Ground	- pole of the battery
Shield	metal cover must be isolated from metal parts of aircraft	do not connect

Note: Conductors length is approx. 200 mm. AWG20.

Maintenance plan:

Maintenance step	Check	Note
After 50 hrs of operation	Cleanliness check of optical components of product	Clean if needed
After 100 hrs of operation	Mechanical integrity of product check	Replace in case the product is damaged
After 500 hrs of operation	Mechanical integrity of product and wiring check	Repair bad wiring or replace product when damaged

Product photos:



Operating condition:

<i>Parameters</i>	<i>Value</i>	<i>Unit</i>	<i>Note</i>
Operating temperature	-20...+50	°C	
Humidity	10...90	%	
Atmospheric pressure	900...1120	hPa	
IP	IP20	-	light device must be protected from the weather
Assembly type	to surface	-	behind the cover glass, metal cover must be isolated from metal parts of aircraft
Working position	any	-	not specified

Important notes and warnings

Thank you for purchasing **Landing Star T2**. For a comfortable and safe use of this product, please pay attention to THE ENTIRE MANUAL, especially the notes and warnings below.

- Although the **Landing Star T2** unit has been thoroughly tested to ensure maximum safety in all conceivable situations, THE RIGHT FUNCTIONALITY DEPENDS ON THE RIGHT INSTALLATION AND SETTINGS.
- Therefore, it is **NECESSARY to READ CAREFULLY and UNDERSTAND THIS MANUAL COMPLETELY.**
- Keep this manual printed in an airplane for cases of emergency or change of ownership.
- **THIS PRODUCT IS NOT APPROVED FOR INSTALLATION IN CERTIFIED AIRPLANES.**
- The pilot **MUST UNDERSTAND** the control of this product before the first flight. **DO NOT** use the product unless you are sure how it works!
- Do not allow unauthorized persons to handle the installed product.
- After installing the product, before the first flight, turn on ALL possible sources of electromagnetic interference on board the aircraft and ensure that the instrument is functioning properly.
- Use of the device in conflict with this manual, with bad wiring, outside the allowed operating conditions, etc., may cause the device to malfunction or damage and endanger flight safety.
- If the product repeatedly indicates an error, do not use it and turn off the power!
- AVOID contact with liquids and chemicals
- Before installation, check the mechanical integrity of the device and its accessories
- DO NOT disassemble the device!
- After installation, carefully check the functionality of the device and its installation
- The responsibility for the installation is entire with the installer.
- Responsibility for performing control actions based on information indicated by the product is full of the operator (pilot). The operator must be able to evaluate an incorrect indication even if the product does not indicate an error.
- Ensure regular maintenance of the aircraft's main battery
- If you do not agree to the notes and warnings above, do not use this product.

Company LAMBERT AERODEVICES s.r.o reserves the right to change or improve the product or manual without prior or subsequent notice.

Document history:

<i>Date (DMY)</i>	<i># Rel</i>	<i>Description</i>	<i>Author</i>
24.9.2019	1	First release of the document	
4.12.2019	2	Notice added	
12.08.2022	3	Include „Important notes and warnings”, LA, operating conditions	NEPOR
22.02.2023	4	introductory image	NEPOR
20.09.2023	5	Ferite bead using	NEPOR



www.lambert-aerodevices.cz